

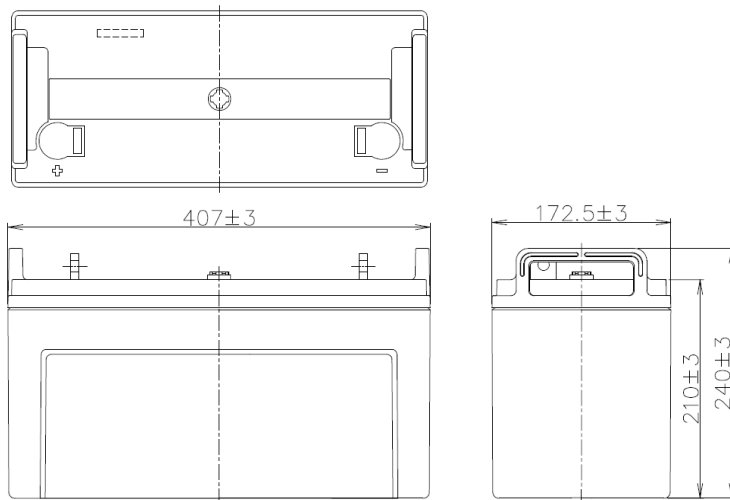

閥調式鉛酸蓄電池(VRLA)
 Valve Regulated Lead Acid Battery

UXH125-12 FR

尺寸 DIMENSION



規範 Specification

<ul style="list-style-type: none"> ☞ 公稱電壓 Nominal Voltage : 12V ☞ 尺寸 Dimension <ul style="list-style-type: none"> 長度 Length : 407±3mm 寬度 Width : 172.5±3mm 高度 Case Height : 210±3mm 總高 Overall Height : 240±3mm ☞ 重量 Weight (約 Approx.) : 39.8 kg ☞ 公稱容量 Nominal Capacity : 125AH / 20HR (25°C) ☞ 內部抵抗 Internal Resistance(Approx.) : 約 3.5 mΩ ☞ 最大充電電流 Max. Charge current : 31.25A ☞ 最大連續放電電流 <ul style="list-style-type: none"> Max. Continuous discharge current : 375A ☞ 5 秒最大放電電流 <ul style="list-style-type: none"> Max. Discharge current in 5 seconds : 750A ☞ 浮動充電 Float Charging : 13.65±0.15V (25°C) ☞ 端子 Terminal : <ul style="list-style-type: none"> 極柱端子 Top terminal : 螺絲式 Bolt (M10) 	<ul style="list-style-type: none"> ☞ 操作溫度範圍 Operating Temperature Range <ul style="list-style-type: none"> 放電 Discharging -15°C to 45°C 充電 Charging -15°C to 45°C 放置 Storage -15°C to 45°C ☞ 期待浮充壽命 Expected float use life (25°C) : 10 years ☞ 容易保養 Easy Maintenance <ul style="list-style-type: none"> 不會洩漏電解液 No electrolyte leakage 確保操作安全性 Ensure safe and efficient operation ☞ 防爆設計 Vent plug provided with built-in ceramic filter <ul style="list-style-type: none"> 阻隔外部火源防止電池破裂 Prevent explosion from outside source of ignition ☞ 電槽材質 Container Material : <ul style="list-style-type: none"> 難燃ABS Flame Retardant ABS · 難燃等級 Flame class : UL94V0 氧氣指數 Oxygen index : 28.0% LOI ☞ 把手設計 Handle Including ☞ 用途 Applications : <ul style="list-style-type: none"> UPS 不斷電系統、電信、緊急照明、警報系統、儀器、太陽能發電系統 UPS(Uninterruptible Power Supply)、Telecommunications、Emergency lighting、Alarm systems、Instrumentation、Solar powered systems
---	---

UXH125-12 FR 性能規格 PERFORMANCE SPECIFICATION : 安培 Amperes and 瓦特 Watts at 25°C (77°F)

F.V.	TIME	5M	10M	15M	20M	30M	45M	1H	2H	3H	4H	5H	8H	10H	20H
		10.80V	W	3379	2725	2350	1960	1491	1115	901	525	375	300	255	164
	A	307	242	206	171	129	96.7	77.8	44.4	31.8	25.1	21.3	13.7	11.3	6.20
10.50V	W	3877	2950	2459	2037	1539	1144	918	531	377	302	256	165	137	75.2
	A	351	267	216	178	134	99.3	79.2	44.9	31.6	25.3	21.5	13.8	11.4	6.25
10.20V	W	4155	3290	2596	2124	1586	1165	924	534	380	304	258	167	138	75.7
	A	389	300	230	187	138	101	79.7	45.1	31.7	25.4	21.6	13.8	11.4	6.26
10.02V	W	4268	3324	2608	2132	1591	1169	925	536	382	306	259	168	139	76.1
	A	404	308	234	189	140	101	79.8	45.3	31.9	25.5	21.7	13.9	11.5	6.30
9.60V	W	4608	3425	2643	2154	1603	1173	928	541	386	309	262	170	140	77.2
	A	450	331	242	194	142	102	80.2	45.7	32.3	25.8	21.9	14.1	11.7	6.39

特性 Characteristics

放電特性 DISCHARGE CHARACTERISTICS

放電曲線 Discharge Characteristics Curves at 25°C

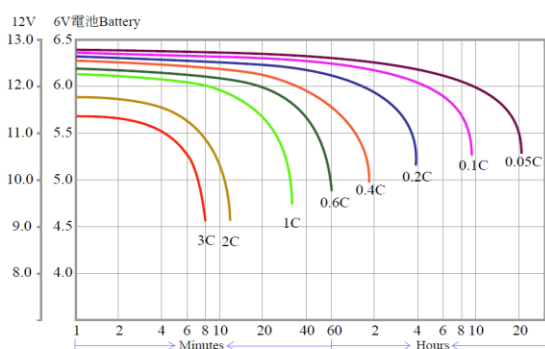

浮充期待壽命 Float Service Life

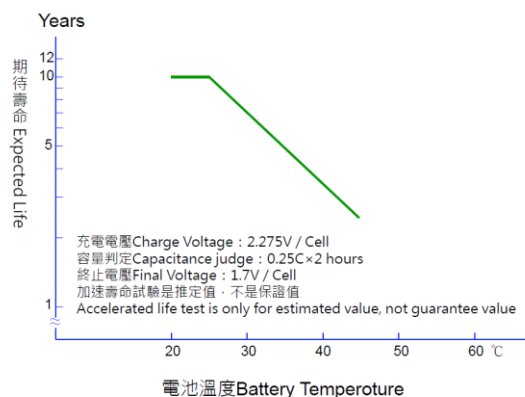

充電特性 CHARGE CHARACTERISTICS

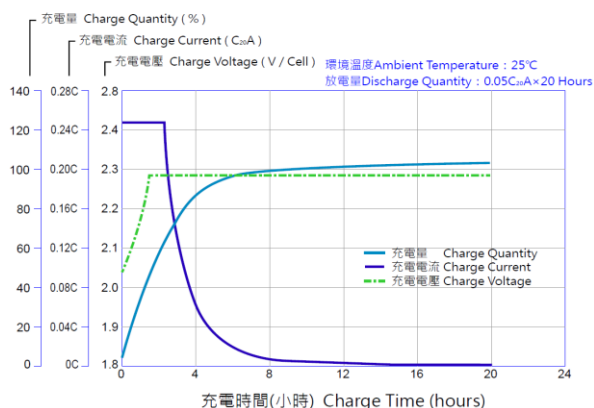

充電電壓 CHARGE VOLTAGE

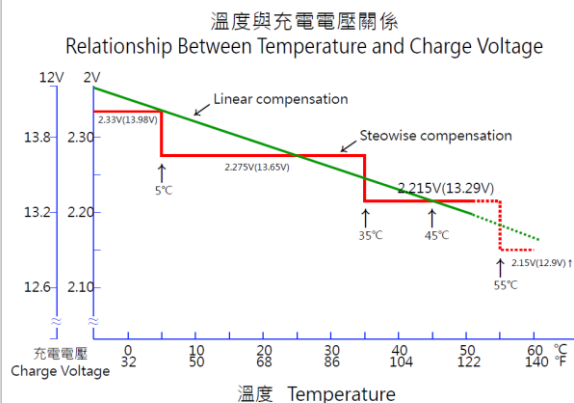

臺灣湯淺電池股份有限公司 新北市新莊區福營路 227 巷 11 號 TEL:(02)2901-8261 FAX:(02)2903-9626
TAIWAN YUASA BATTERY CO.,LTD No.11, Ln. 227, Fuying Rd., Xinhuang Dist., New Taipei City <http://www.yuasa.com.tw/>