

NPA75-12I

尺寸 DIMENSION

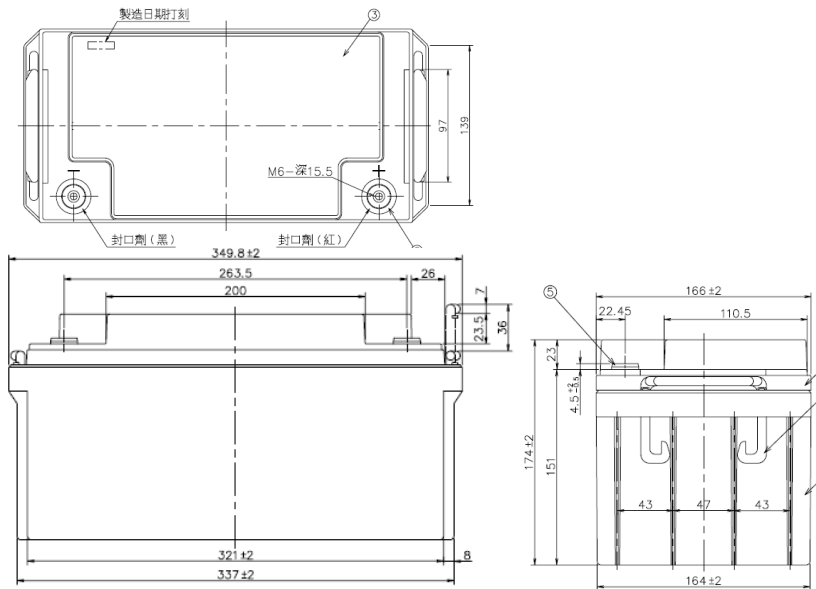

規範 Specification

- 公稱電壓 Nominal Voltage : 12V
- 操作溫度範圍 Operating Temperature Range
 - 放電 Discharging -15°C to 45°C
 - 充電 Charging -15°C to 45°C
 - 放置 Storage -15°C to 45°C
- 尺寸 Dimension
 - 長度 Length : 349.8±2mm
 - 寬度 Width : 166±1mm
 - 高度 Case Height : 174±2mm
 - 總高 Overall Height : 174±2mm
- 期待浮充壽命 Expected float use life (25°C) : 10 years
- 重量 Weight (約 Approx.) : 23.5 kg
- 容易保養 Easy Maintenance
 - 不會洩漏電解液 No electrolyte leakage
 - 確保操作安全性 Ensure safe and efficient operation
- 公稱容量 Nominal Capacity : 75AH / 20HR (25°C)
- 電槽材質 Container Material :
 - 難燃ABS Flame Retardant ABS · 難燃等級Flame class : UL94V0
 - 氧氣指數Oxygen index : 28.0% LOI
- 內部抵抗 Internal Resistance(Approx.) : 約 7.5 mΩ
- 把手設計 Handle Including
- 最大充電電流 Max. Charge current : 18.75A
- 用途 Applications :
 - UPS 不斷電系統、電信、緊急照明、警報系統、儀器、太陽能發電系統
 - UPS(Uninterruptible Power Supply) · Telecommunications · Emergency lighting · Alarm systems · Instrumentation · Solar powered systems
- 最大連續放電電流
 - Max. Continuous discharge current : 225A
- 5 秒最大放電電流
 - Max. Discharge current in 5 seconds : 450A
- 浮動充電 Float Charging : 13.65±0.15V (25°C)
- 端子 Terminal :
 - 極柱端子Top terminal : 螺絲式 Bolt (M6)

NPA75-12I 性能規格 PERFORMANCE SPECIFICATION : 安培 Amperes and 瓦特 Watts at 25 °C (77 °F)

F.V.	TIME	5M	10M	15M	20M	30M	45M	1H	2H	3H	4H	5H	8H	10H	20H
	10.80V	W	2419	1820	1464	1207	909	673	538	317.5	223.3	184.8	147.5	101.9	81.5
	A	216	162	127	104	78	57	45.8	26.7	18.6	15.6	12.7	84.3	6.80	3.6
10.50V	W	2650	1900	1509	1241	931	687	548	324	227.7	188.6	149.5	104	82.0	42.4
	A	241	170	131	107	80	58	46.6	27.2	18.9	15.9	12.9	8.6	6.91	3.75
10.20V	W	2800	2000	1552	1270	948	696	552	327.2	229	190.5	152.2	105.0	82.9	43.3
	A	260	182	136	110	82	59	46.9	27.5	19.1	16.1	13.0	8.69	6.95	3.8
10.02V	W	2902	2038	1567	1279	953	698	553	330.5	230.2	192.4	153.6	106.5	83.6	44.3
	A	272	185	137	111	82.3	59.3	47.0	27.7	19.2	16.2	13.1	8.77	6.98	3.85
9.60V	W	3179	2140	1608	1305	966	704	554	333.8	231.4	194.3	155.0	107.1	84.3	45.2
	A	305	193	141	113	83	60	47.2	28.0	19.3	16.4	13.2	8.86	7.0	3.9

特性 Characteristics

放電特性 DISCHARGE CHARACTERISTICS

放電曲線 Discharge Characteristics Curves at 25°C

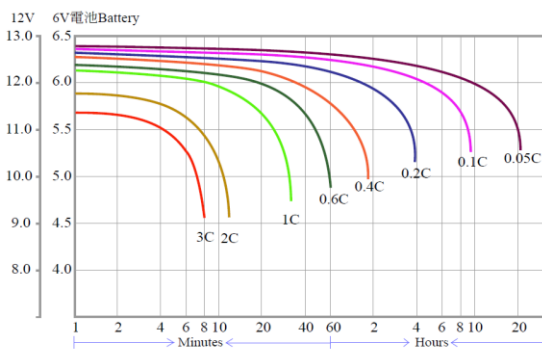

浮充期待壽命 Float Service Life

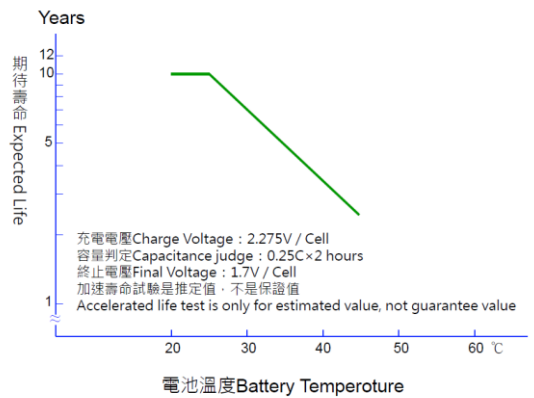

充電特性 CHARGE CHARACTERISTICS

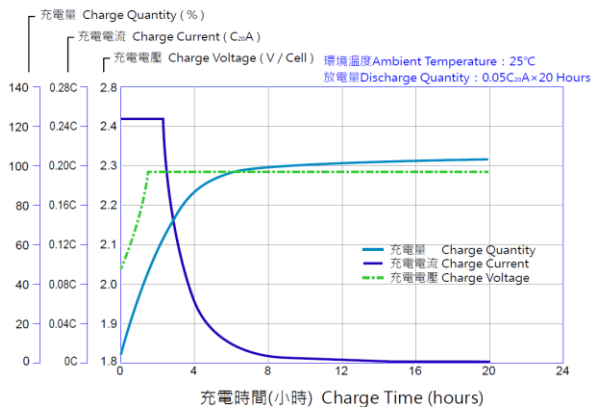

充電電壓 CHARGE VOLTAGE

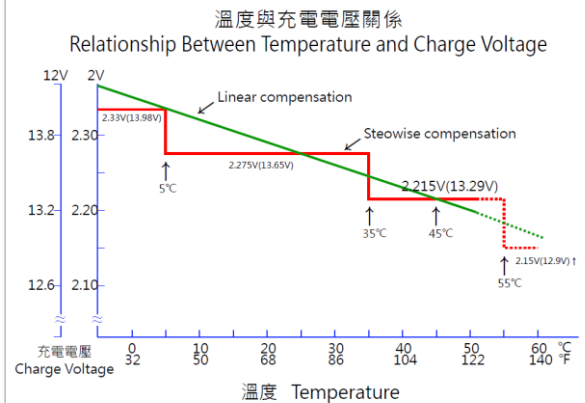

臺灣湯淺電池股份有限公司 新北市新莊區福營路 227 巷 11 號 TEL:(02)2901-8261 FAX:(02)2903-9626
 TAIWAN YUASA BATTERY CO.,LTD No.11, Ln. 227, Fuying Rd., Xinzhuang Dist., New Taipei City http://www.yuasa.com.tw/